

# Water Resources Preservation Grant Program Upper Guadalupe River Authority



## The Need for Nature-based Infrastructure in Kerr County

---

As Kerr County's population increases, the need to provide adequate protection for our water resources becomes more urgent. Growth of residential and commercial areas usually accompanies the removal of vegetation and the addition of impervious surfaces such as roofs, parking lots, and streets. These modifications increase the potential for pollution to enter waterways because the areas of soil and vegetation that previously intercepted rain and absorbed runoff have been reduced or eliminated. As a result, rainfall now quickly flows across the impervious surfaces and accumulates dirt, grease, oil, bacteria, and other contaminants. Unimpeded, stormwater runoff will carry contaminants from throughout the watershed directly into our rivers and streams and negatively affect the health of these receiving waterbodies.

Development can include design elements that reduce the amount of stormwater runoff that enters waterways by implementing strategies to intercept runoff and retain the water on the land where possible. Contaminants that influence water quality in our river and streams rarely occur at the water's edge but from anywhere within the watershed making it important to intercept runoff as close to where it originates as possible. Additionally, riparian areas, the band of native vegetation along the river and streams, are the last line of defense in protecting waterbodies from stormwater runoff and pollution. Native riparian vegetation acts as a filter, trapping sediments and other pollutants before they reach the river or streams. If riparian areas are disturbed or removed, polluted stormwater will flow directly into the waterway. Through this program, the Upper Guadalupe River Authority (UGRA) will work with individuals and businesses to implement design strategies that can reduce stormwater runoff and protect the health of Kerr County waterways.

## Water Resources Preservation Grant Program

---

### Description

The Water Resources Preservation Grant Program is an incentive program funded by UGRA. The program provides cost share funding for design and construction of stormwater management practices commonly referred to as best management practices (BMPs). The program provides rebates for a portion of the cost of specific management practices that reduce, infiltrate, filter, and delay stormwater runoff. These types of practices fall under the umbrella terms of Low Impact Development (LID), nature-based solutions, and Green Stormwater Infrastructure (GSI). Stormwater management practices must be designed and constructed using the guidance provided in this document. The program is open to new construction or retrofit of existing property.

### Benefits

Addressing stormwater-related issues on site is one of the most critical aspects of sustainable design and can provide major benefits to ecological health while also minimizing costs and negative impacts to other local infrastructure. Both the amount of rainfall within individual storm events as well as intensity of droughts have increased over time, therefore careful attention to the management and conservation of water is of the utmost importance.

The methods proposed by this program offer specific design solutions to stormwater-related concerns. However, it is important to understand the driving philosophy behind these methods, and what steps to take to ensure they are successful within a larger water-conscious strategy.

#### *Runoff Reduction:*

The first step is to reduce and slow stormwater runoff. Every project should aim to retain all rainfall volume on site, reducing flooding and pressure on stormwater infrastructure within the watershed. Reducing runoff can initially be achieved by reducing impervious surfaces (whether through decreasing

the overall hardscape or through utilizing porous materials where possible), and by disconnecting impervious surfaces or providing breaks in them to slow the flow of runoff.

Additional tips for reducing the detrimental effects of runoff include keeping it as sheet flow as much as possible. Sheet flow is when runoff forms a wide shallow flow of water as opposed to a narrow, concentrated flow of water. Once flow is concentrated, its velocity typically increases along with the potential for damaging effects. Be mindful of locating drainage areas and establishing flow lines. Design impervious surfaces to drain to adjacent planted storage or treatment areas. Linear impervious surfaces like walkways or roads should be oriented perpendicular to the slope.

Add planting areas beyond requirements as this not only has a massive impact on the reduction and absorption of runoff but also provides additional ecosystem benefits including habitat creation and heat island reduction. Healthy, uncompacted soils are critical for the absorption of runoff and to support vigorous plant communities.

#### *Distributed Treatment:*

The next step is to treat runoff using stormwater best management practices distributed throughout the site. Thoughtful design choices to reduce runoff will result in smaller volumes of stormwater therefore smaller areas required to treat it. The methods available in this program detail several strategies for slowing, storing, and treating stormwater including bioretention and rainwater harvesting.

#### *Centralized Treatment:*

Runoff reduction and distributed treatment are sometimes not enough to treat all stormwater runoff at a specific location. When there is more runoff volume than can be treated in distributed controls, then any excess water should be collected and routed to a more centralized treatment on site.

#### *Treatment Levels:*

This project specifically targets Total Suspended Solids (TSS) and Bacteria. TSS is also commonly referred to as sediment and causes water to look cloudy. TSS may also carry other constituents that adhere to the fine particles and can be treated using filtering and settling. Bacteria is a general term for single cell organisms that exist everywhere in the environment. Some species of bacteria cause waterborne diseases. Bacteria can replicate exponentially under ideal conditions. Harmful bacteria in stormwater that drains to creeks, streams, rivers, and lakes can raise the level of bacteria in the water to levels that are unsafe for human contact.

Standard target removal rates are 80% for Total Suspended Solids and 60% for bacteria. This program presumes these rates of removal for bioretention, rainwater harvesting, vegetated filter strips and permeable pavement designed and constructed using guidance outlined in Appendix A – Technical Design Guidance. Riparian Buffers are not presumed to remove this level of TSS nor bacteria.

#### *Education:*

Raise public awareness of nonpoint source runoff as it relates to impervious cover. Show how simple nature-based treatment methods can be implemented to treat runoff before it enters creeks, streams, and the Guadalupe River.

## Goals

The goals of this program include the following using guidance outlined in Appendix A – Technical Design Guidance:

1. Improve the quality of water in the Guadalupe River by reducing bacteria and sediment carried into the Guadalupe River by non-point source runoff.
2. Lessen the impact of local flooding by reducing stormwater runoff volume.
3. Reduce stormwater runoff velocity.
4. Preserve functioning riparian areas.
5. Engage local design professionals, including architects, landscape architects, and civil engineers to increase use of nature-based infrastructure practices.

6. Create awareness of how stormwater runoff affects river health resulting in long-term behavioral change to mitigate impacts.

## Program Details

---

- Interested applicants should contact UGRA and schedule a pre application meeting as soon as possible during the project planning process
- One application per project (applicant can reapply for future construction phases and those applications will be evaluated as standalone projects)
- Applications are accepted year-round
- No limit on number of stormwater management practices per project
- Design and construction must follow guidance from this document
- Design is based on runoff volume from a 1.5" 24-hour event
- Projects treating at least 60% of runoff from impervious surfaces will receive priority Projects are scored based on a published rubric
- Eligible projects must have a minimum score of 10 on the published rubric
- List of eligible stormwater management practices include:
  - Bioretention
  - Permeable Pavement
  - Rainwater Harvesting / Cistern
  - Vegetated Filter Strip
  - Riparian Buffer
  - Other treatment options including proprietary devices with written approval from UGRA
- Project must include installation of interpretive signage for each management practice (UGRA will provide selected applicants with sign content).
- Rebate:
  - Minimum rebate \$20,000
  - Maximum rebate \$150,000
  - Number of projects approved per year is contingent upon funds budgeted by the UGRA Board
  - Rebate is only for design and construction of stormwater management practices
  - Rebate agreement signed by landowner is required which will include an expectation for continued operation and maintenance of the practices for which the rebate was provided.
  - Rebate funds are paid after project is complete and an inspection by UGRA personnel is conducted
  - Rebate is payable to landowner only

## Eligibility

The program is open to all projects located within Kerr County, except:

1. Single family residential projects
2. Small projects with stormwater treatment cost estimate less than \$20,000

## Application

To apply for the program, submit the following documents:

1. Complete **Application Form**
2. Written **Project Narrative** that includes the following information:
  - a. Project description
  - b. Details on how project meets the goals of the program
  - c. Estimated cost of nature-based practices
  - d. Estimated amount of cost share rebate requested
  - e. Impact on receiving water body (i.e. anticipated reduction in adverse impacts such as erosion or sedimentation)
  - f. Details on operation and maintenance
  - g. Project location, easements, public access

- h. Details on commitment to the project (i.e. anticipated educational opportunities to promote BMPs, owner's financial commitment to BMPs, prior experience with similar BMPs)
- i. Details on drainage areas and BMP treatment
- 3. **Project Drawing**, a plan view drawing that includes the following information in order to illustrate a conceptual design (sealed designs are not required for the application).
  - a. Property boundary and area
  - b. Boundaries and dimensions of all impervious areas
  - c. Boundaries and dimensions of all drainage areas
  - d. Boundaries and dimensions of all existing riparian areas (if applicable)
  - e. Boundaries and dimensions of all riparian areas proposed for restoration and preservation (if applicable)
  - f. Existing contours with elevation
  - g. Proposed contours with elevation
  - h. Hydrologic Soil Group (HSG) boundary (refer to references for info)
  - i. Hydrologic Soil Group (HSG) label
  - j. Proposed treatment best management practice(s)
  - k. Cross-section for each best management practice(s). This can be a conceptual cross section based on the example designs in Appendix B of the program guidance.
  - l. All BMP dimensions
  - m. Calculations for Target Volume
  - n. Calculations for Treatment Volume
- 4. Complete **Treatment Worksheet**

An application is complete if it has an **Application Form** with all fields completed, a written **Project Narrative** with all required information, a **Project Drawing** with all required information, and a **Treatment Worksheet** with all the required information. You will be notified when the application is considered accepted.

## Project Evaluation

Projects are evaluated based on the following categories. Please refer to the UGRA Water Resources Preservation Grant Program Rubric for details.

1. Project Description – How well a proposed project meets the goals of the program
2. Amount of treatment – What percentage of impervious surfaces are treated by the proposed BMPs (Projects treating at least 60% will receive priority)
3. Impact on receiving body – Distance to closest receiving waterbody
4. Operation and maintenance – Commitment to preserving operation of BMPs
5. Location – Located on UGRA land, obtained easement, publicly accessible and visible
6. Commitment – Commitment to the goals of the program. Examples include corporate commitment, financial commitment, treatment beyond requirements, O&M commitment beyond requirements, enhanced demonstration of project – social media links, tours, etc.
7. Riparian function – If applicable, does riparian area meet minimum size

## Project Selection

Project applications are accepted year-round. Projects are scored using the UGRA Water Resources Preservation Grant Program Rubric and top scoring project(s) are selected to proceed to enter into a cost share funding agreement. A minimum score of 10 and at least 1 point in each category of the rubric is required for a project to be selected (unless the strategy for implementation is restoration of riparian areas, then less than 1 point in a category of the rubric is allowed). Applicants will be notified by UGRA staff when selected. Selected projects will require close coordination with UGRA to work out project details.

## References

---

- Texas Aquifers - [https://www.twdb.texas.gov/groundwater/special\\_projects/valverde/docs/TexasAquiferStudy\\_FINAL\\_forWeb.pdf](https://www.twdb.texas.gov/groundwater/special_projects/valverde/docs/TexasAquiferStudy_FINAL_forWeb.pdf)
- Urban Stormwater Quality, Pollutant Loads - <https://pubs.usgs.gov/wri/wri984158/pdf/wri98-4158.pdf>
- Edwards Aquifer Rules - <https://www.tceq.texas.gov/publications/rg/rg-348>
- San Antonio River Basin Low Impact Development Technical Design Guidance Manual - [https://www.sariverauthority.org/wp-content/uploads/2023/09/lid\\_tech\\_manual-3rded-manual.pdf](https://www.sariverauthority.org/wp-content/uploads/2023/09/lid_tech_manual-3rded-manual.pdf)
- Texas Commission on Environmental Quality, Stormwater Permits - <https://www.tceq.texas.gov/permitting/stormwater>
- Environmental Protection Agency, Summary of Clean Water Act - <https://www.epa.gov/laws-regulations/summary-clean-water-act>
- Riparian Restoration on Farms and Ranches in Texas - <https://bexar-tx.tamu.edu/files/2012/07/Riparian-Restoration-on-Farms.pdf>
- Texas Riparian Association - <https://texasriparian.org/>
- Conservation Buffers - [https://www.fs.usda.gov/nac/buffers/docs/conservation\\_buffers.pdf](https://www.fs.usda.gov/nac/buffers/docs/conservation_buffers.pdf)
- Natural Resources Conservation Service - Web Soil Survey (Hydrologic Soil Group) - <https://websoilsurvey.sc.egov.usda.gov/App/WebSoilSurvey.aspx>
- Riparian Zone Restoration - <https://austintexas.gov/faq/riparian-zone-restoration>
- Riparian Function and Benefits in Austin, Texas - [https://austintexas.gov/watershed\\_protection/publications/document.cfm?id=213558](https://austintexas.gov/watershed_protection/publications/document.cfm?id=213558)
- Grow Zones - [https://www.hillcountryalliance.org/wp-content/uploads/2021/09/HCA\\_Riparian\\_GrowZones\\_2021.pdf](https://www.hillcountryalliance.org/wp-content/uploads/2021/09/HCA_Riparian_GrowZones_2021.pdf)
- Remarkable Riparian – <http://remarkableriparian.org/YourRemarkableRiparianOwnersManual>
- Plant database - <https://www.wildflower.org/plants>
- Noxious Plants - [https://texreg.sos.state.tx.us/public/readtac\\$ext.TacPage?sl=R&app=9&p\\_dir=&p\\_rloc=&p\\_tloc=&p\\_ploc=&pg=1&p\\_tac=&ti=4&pt=1&ch=19&rl=300](https://texreg.sos.state.tx.us/public/readtac$ext.TacPage?sl=R&app=9&p_dir=&p_rloc=&p_tloc=&p_ploc=&pg=1&p_tac=&ti=4&pt=1&ch=19&rl=300)  
[https://tpwd.texas.gov/huntwild/wild/species/exotic/prohibited\\_aquatic.phtml#plant](https://tpwd.texas.gov/huntwild/wild/species/exotic/prohibited_aquatic.phtml#plant)
- Riparian Management Plan – [https://tpwd.texas.gov/landwater/water/aquatic-invasives/aquatic\\_invasive\\_plants.phtml](https://tpwd.texas.gov/landwater/water/aquatic-invasives/aquatic_invasive_plants.phtml)  
[https://tpwd.texas.gov/landwater/water/aquatic-invasives/streamside\\_restoration.phtml](https://tpwd.texas.gov/landwater/water/aquatic-invasives/streamside_restoration.phtml)
- Plants for a Riparian Buffer – <http://remarkableriparian.org/YourRemarkableRiparianOwnersManual>  
[https://www.austintexas.gov/sites/default/files/files/Watershed/riparian/riparian\\_template.pdf](https://www.austintexas.gov/sites/default/files/files/Watershed/riparian/riparian_template.pdf)  
[https://www.hillcountryalliance.org/wp-content/uploads/2021/09/HCA\\_RiparianPlantingGuide\\_2021.pdf](https://www.hillcountryalliance.org/wp-content/uploads/2021/09/HCA_RiparianPlantingGuide_2021.pdf)

## Appendix A – Technical Design Guidance

---

Technical guidance for each Best Management Practice (BMP) refers to a local established guide and includes further additions and deletions to tailor the practice for this program. Additions and deletions are made to simplify the process or customize it for the Upper Guadalupe River watershed.

### Target Volume Calculation:

The **Treatment Worksheet** can calculate Target Volume for individual drainage areas and the entire project. The following equation is used to calculate the Target Volume for each impervious drainage area.

$$\text{Target Volume (cubic feet)} = \text{drainage area (square feet)} \times \text{treatment rainfall (feet)} \text{ [Equation 1]}$$

Where:

Target Volume	= target volume to detain and treat
drainage area	= impervious area that flows to the treatment area
treatment rainfall	= 85-90% total average annual rainfall volume in storms up to this depth
depth	= 1.5"/12" = 0.125 ft

Example: What is the target volume for a roof with an area of 1,250 square feet?

$$\text{Target Volume} = 1,250 \text{ square feet} \times 0.125 \text{ feet} = \mathbf{156.25 \text{ cubic feet}}$$

### Bioretention

Bioretention areas are shallow basins that capture, hold and infiltrate stormwater runoff. Bioretention areas contain a forebay or pretreatment area to slow flow and capture large particles of sediment for easy maintenance. To infiltrate stormwater runoff, bioretention areas must have soils with a minimum infiltration rate. In areas where soils are not able to infiltrate at the minimum rate, the soils must be replaced using an approved bioretention soil mix. Bioretention areas are typically planted with native plants selected based on location within the bioretention area. Bioretention areas may have underdrains depending on local soils and other conditions. For the purposes of this program bioretention also includes bioswales which are linear in shape.

Follow design process from [San Antonio River Basin Low Impact Development Technical Design Guidance Manual 3<sup>rd</sup> Edition](#). (Design Process – Appendix B Page 165)

Additions and Deletions:

- Design Step 1 – Determine BMP Treatment Volume using UGRA Target Volume (Equation 1)
- Refer to reference design in Appendix B of this document

Use the following equation to calculate Treated Volume for bioretention.

$$\text{Treated Volume (cubic feet)} = A \text{ (square feet)} \times \text{Deq (feet)} \text{ [Equation 2]}$$

Where:

Treated Volume	= volume of stormwater treated
A	= area of bioretention basin (bottom)
Deq	= equivalent depth = ponding depth (feet) + [depth of bioretention soil (feet) x porosity] + [depth of drainage rock (feet) x porosity] = (D <sub>surface</sub> ) + (n <sub>media</sub> x D <sub>media</sub> ) + (n <sub>gravel</sub> x D <sub>gravel</sub> )
n <sub>media</sub>	= 0.35 for bioretention soil and sand
n <sub>gravel</sub>	= 0.4 for gravel/stone
D <sub>media</sub>	= depth of bioretention soil + sand
D <sub>gravel</sub>	= depth of drainage gravel/stone

## Permeable Pavement

Follow design process from [San Antonio River Basin Low Impact Development Technical Design Guidance Manual 3<sup>rd</sup> Edition](#). (Design Process – Appendix B Page 187)

Additions and Deletions:

- *Design Step 1* – Determine BMP Treatment Volume using UGRA Target Volume (Equation 1)
- *Design Step 2* – Fully lined systems are only required if sited near karst geology. Maximum drainage area to permeable area ratio 2:1. For example 200 square feet of concrete parking can drain to a permeable area of 100 square feet resulting in 300 square feet used for calculating Target Volume.
- *Design Step 3* – Eligible materials for this program include: Permeable interlocking concrete pavers (PICP), concrete grid pavers, plastic grid systems and pervious concrete. Porous asphalt is NOT eligible.
- Refer to reference design in Appendix B – Example Designs of this document.

Use the following equation to calculate Treated Volume for permeable pavement.

$$\text{Treated Volume (cubic feet)} = A \text{ (square feet)} \times \text{Deq (feet)} \text{ [Equation 3]}$$

Where:

Treated Volume	= volume of stormwater treated
A	= area of bioretention basin (bottom)
Deq	= equivalent depth = [depth of drainage rock (feet) x porosity] + [depth of sand (feet) x porosity] = (n <sub>gravel</sub> x D <sub>gravel</sub> ) + (n <sub>media</sub> x D <sub>sand</sub> )
n <sub>sand</sub>	= porosity, 0.35 for sand
n <sub>gravel</sub>	= porosity, 0.4 for drainage gravel/stone
D <sub>sand</sub>	= depth of sand (feet)
D <sub>gravel</sub>	= depth of drainage gravel/stone (feet)

## Rainwater Harvesting / Cistern

Rainwater harvesting is the collection and retention of stormwater runoff from impervious surfaces, typically roofs. Collected runoff is stored temporarily in an appropriate receptacle, either above or below ground. Collected runoff can be used for irrigation or slowly released to an area where it can infiltrate. Careful consideration is taken to make sure receptacles have appropriate foundations and are equipped to prevent the spread of disease vectors, especially mosquitos.

Follow design process from [San Antonio River Basin Low Impact Development Technical Design Guidance Manual 3<sup>rd</sup> Edition](#). (Design Process – Appendix B Page 235)

Additions and Deletions:

- *Design Step 1* – Determine BMP Treatment Volume using UGRA Target Volume (Equation 1)
- *Design Step 2* – Concrete foundation is required for cisterns exerting greater than 2000 pounds per square foot. All foundations must be reviewed by an appropriate design professional which may require a geotechnical evaluation to determine the structural load capacity of the soil. Foundation design must be part of signed and sealed construction plans.
- *Design Step 3* – The Water Quality Volume must be released to a vegetated area meeting the requirements outlined in Table B-9-2 on page B-149. If the Water Quality Volume is used for irrigation purposes on a system with an irrigation controller, then it may be held and used during scheduled irrigation cycles, otherwise the Water Quality Volume must be released to an appropriate vegetated area over a period of 2 – 6 days (48 – 144 hours). The Water Quality Volume must never be held more than 14 days after the last rain event to provide storage for future rain events.
- Refer to reference design in Appendix B – Example Designs of this document

Use the following equation to calculate Treated Volume for Rainwater Harvesting.

*Treated Volume (cubic feet) = volume of cistern [Equation 4]*

Where:

Treated Volume = volume of stormwater treated  
Volume of cistern = stated volume of cistern

## Vegetated Filter Strip

A vegetated filter strip is a vegetated area that receives runoff from an adjacent impervious area, usually a street or parking lot. The drainage area must be level and provide surface flow perpendicular to the edge draining to the vegetated filter strip. The vegetation in the strip can be turf or a combination of native plants if the plant size and placement does not concentrate flow of runoff in the filter strip. There are limitations to slope and dimensions; refer to design reference.

Follow design process from [Complying with the Edwards Aquifer Rules: Technical Guidance on Best Management Practices](#) (Design Process – Page 3-55)

Additions and deletions:

- Temporary Vegetated Filter Strips are not eligible for this rebate program.

Vegetated filter strips infiltrate and treat some stormwater. This program assumes 60% of the generated volume is considered treated. Use the following equation to calculate Treated Volume.

*Treated Volume (cubic feet) = drainage area (square feet) x treatment rainfall (feet) x 60% [Equation 5]*

## Riparian Buffer

A riparian buffer includes the soil, rocks, and vegetation located on the bed and banks of creeks, streams, rivers and lakes. This area functions to filter stormwater as it drains to the waterbody. Vegetation on the banks stabilize the soil and slow flood flows while retaining groundwater and filtering runoff. Cobble, rocks and dead vegetation in the channel slow the flow in channels which also reduces erosion.

The design guidance to restore or preserve a Riparian Buffer is outlined below. Use this resource to learn about riparian areas:

[Your Remarkable Riparian Owner's Manual](#)

*Design Step 1 – Determine location of riparian buffer.*

A riparian buffer must be located adjacent to the receiving waterbody. The buffer length follows the boundary between the water body and the project site. The buffer width is the distance along the boundary for the entire length of the buffer.

*Design Step 2 – Determine dimensions*

- Riparian Buffer Length: the length of the riparian buffer may be the entire length of the property that borders the waterbody. Up to 15% of the total border length can be set aside as a targeted access point to the waterbody.
  - Riparian Buffer Length = length of boundary between property and waterbody – length of targeted access point
- Riparian Buffer Width: the width of the riparian buffer is determined using the equation below:
  - Riparian Buffer Width = Edge of water body to boundary of riparian buffer
  - Applicants are encouraged to design using the entire Riparian Buffer Width of at least 30 feet, 50 feet or more is preferred.

*Design Step 3 – Conduct plant inventory of riparian buffer*

Conduct a plant survey that details quantity and species of plants. Spreading plants, grasses and ground covers can be specified using area estimates. List of plant resources:

- <https://www.wildflower.org/plants/>

*Design Step 4 – Identify noxious and invasive plants identified by Texas Department of Agriculture*



Compare the plant inventory from Step 4 to the list of Texas Department of Agriculture Noxious and Invasive Plants. List available at these links:

- [https://texreg.sos.state.tx.us/public/readtac\\$ext.TacPage?sl=R&app=9&p\\_dir=&p\\_rloc=&p\\_tloc=&p\\_ploc=&pg=1&p\\_tac=&ti=4&pt=1&ch=19&rl=300](https://texreg.sos.state.tx.us/public/readtac$ext.TacPage?sl=R&app=9&p_dir=&p_rloc=&p_tloc=&p_ploc=&pg=1&p_tac=&ti=4&pt=1&ch=19&rl=300)
- [https://tpwd.texas.gov/huntwild/wild/species/exotic/prohibited\\_aquatic.phtml#plant](https://tpwd.texas.gov/huntwild/wild/species/exotic/prohibited_aquatic.phtml#plant)

*Design Step 5 – Prepare management plan*

Develop a management plan which addresses the following:

- Restrict activities and uses for riparian buffer.
  - Area should not be used for any of the following activities:
    - Water access
    - Trails
    - Boat ramps
    - Parking
    - Any activities that may compress soil
    - Mowing – See Riparian Buffer Operation and Maintenance
- Management of noxious and invasive plants
- Restoration plan (if applicable)
  - Develop a planting plan for native trees, shrubs, and ground cover

Resources available at these links:

- [https://tpwd.texas.gov/landwater/water/aquatic-invasives/aquatic\\_invasive\\_plants.phtml](https://tpwd.texas.gov/landwater/water/aquatic-invasives/aquatic_invasive_plants.phtml)
- [https://tpwd.texas.gov/landwater/water/aquatic-invasives/streamside\\_restoration.phtml](https://tpwd.texas.gov/landwater/water/aquatic-invasives/streamside_restoration.phtml)
- [Remarkable Riparian Owner's Manual](#)
- [https://www.austintexas.gov/sites/default/files/files/Watershed/riparian/riparian\\_template.pdf](https://www.austintexas.gov/sites/default/files/files/Watershed/riparian/riparian_template.pdf)
- [https://www.hillcountryalliance.org/wp-content/uploads/2021/09/HCA\\_RiparianPlantingGuide\\_2021.pdf](https://www.hillcountryalliance.org/wp-content/uploads/2021/09/HCA_RiparianPlantingGuide_2021.pdf)

## Appendix B – Example Designs

Design examples for each method are outlined below. Two separate sites are used for the examples. The first site, shown below, is located adjacent to the Guadalupe River and provides examples of stormwater treatment using bioretention, permeable pavement (pavers), cisterns and a riparian buffer. The second site is an existing parking lot redesigned to use a vegetated filter strip to treat stormwater runoff. The examples do not include subsurface utility engineering (SUE) surveys of existing utility conflicts and should only be referenced as fictitious examples. This is the level of design required to be submitted as the **Project Drawing**. The **Project Drawing** can be done by hand.

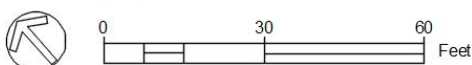

## Bioretention – Site 1

A parcel is developed to include a building, entry drive, and parking. The goal of this project is to maximize the treatment of stormwater runoff using as many methods as possible. After laying out the new design, a bioretention area is selected to treat the runoff from part of the drive and parking area. The soil report for this site shows most of the site is Hydrologic Soil Group D. This means the soils are mostly clay with insufficient infiltration rate to soak up the runoff, therefore an underdrain is added. Underdrains must either daylight downslope or connect to an existing stormwater network. In this case the underdrain can daylight downslope.

The first step is to determine the target volume as shown below:

$$\begin{aligned} \text{Target Volume (cubic feet)} &= \text{drainage area (square feet)} \times \text{treatment rainfall (feet)} \text{ [Equation 1]} \\ &= 4124 \text{ SF} \times 0.125 \text{ F} \\ &= 515.5 \text{ CF} \end{aligned}$$

Since the goal is to maximize treatment, the bioretention area is designed to treat 100% of the Target Volume. The Treated Volume is calculated using equations B-1-2 and B-1-3 on pages 169 - 170 of the [San Antonio River Basin Low Impact Development Technical Design Guidance Manual 3<sup>rd</sup> Edition](#), as shown below. The cross-section shown below is used for this example and meets all required dimensions.

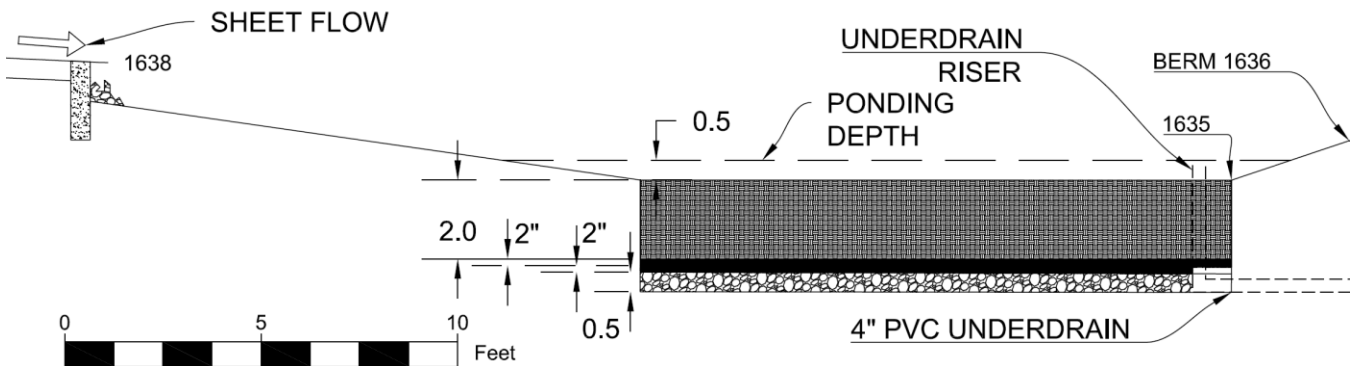

First, calculate the equivalent depth ( $D_{eq}$ ). [Equation 2]

$$D_{eq} = (D_{surface}) + (n_{media} \times D_{media}) + (n_{gravel} \times D_{gravel})$$

Where  $n_{media} = 0.35$  for bioretention soil and sand  
 $n_{gravel} = 0.4$  for #2, #57 stone

$$\begin{aligned} D_{eq} &= 0.5 \text{ F [ponding]} + (0.35 \times 2 \text{ F}) \text{ [BR soil]} + (0.35 \times 0.17 \text{ F}) \text{ [sand]} + (0.4 \times 0.17) \text{ [#2 stone]} + (0.4 \times 0.5 \text{ F}) \text{ [#57 stone]} \\ &= 0.5 \text{ F} + 0.7 \text{ F} + .0595 \text{ F} + .068 \text{ F} + 0.2 \\ &= 1.53 \text{ F} \end{aligned}$$

Next, calculate the required treatment area ( $A$ ).

$$A = \text{Volume} / \text{equivalent depth}$$

In this case we want to treat the entire target volume, so Volume = Target Volume.

$$\begin{aligned} A &= 515.5 \text{ CF} / 1.53 \text{ F} \\ &= 336.9 \text{ SF} \end{aligned}$$

Finally, adjust the dimensions to fit the available site. In this case, the dimensions are set to 16 F x 22 F which equals 352 SF, slightly larger than the required area.



A closer view of the bioretention area shows the modified grading to make room for the bioretention area and the dashed lines show where the underdrain daylights down slope.



# Permeable Pavement – Site 1

The entire new drive is treated using permeable pavement. The site has clay soils with Hydrologic Soil Group D, therefore an underdrain is required. There is room to route the underdrain around the tree through the parking lot and daylight it downslope. The design has elected to use permeable interlocking concrete pavers for aesthetics and durability. The new drive and walkway are designed to drain to the permeable pavers. The total area of the drive and walkway is 3630 SF. Note: The area with permeable pavers is still considered impervious for calculating the Target Volume.

The first step is to determine the target volume as shown below:

$$\begin{aligned} \text{Target Volume (cubic feet)} &= \text{drainage area (square feet)} \times \text{treatment rainfall (feet)} \text{ [Equation 1]} \\ &= (\text{DA1} + \text{DA2} = 3324 \text{ SF}) \times 0.125 \text{ F} \\ &= 415.5 \text{ CF} \end{aligned}$$

Next, the maximum ratio of drainage area to pervious area is 2:1. Therefore, 1/3 of the total area must be pervious pavers.

$$\begin{aligned} \text{Area of pervious pavers (SF)} &= 1/3 \times \text{total treatment area (SF)} \text{ [Equation 3]} \\ &= 1/3 \times 3324 \text{ SF} \\ &= 1108 \text{ SF} \end{aligned}$$

The pervious paver boundary is sized to match. Both the impervious drainage area and the pervious area are labeled. See close-up below.

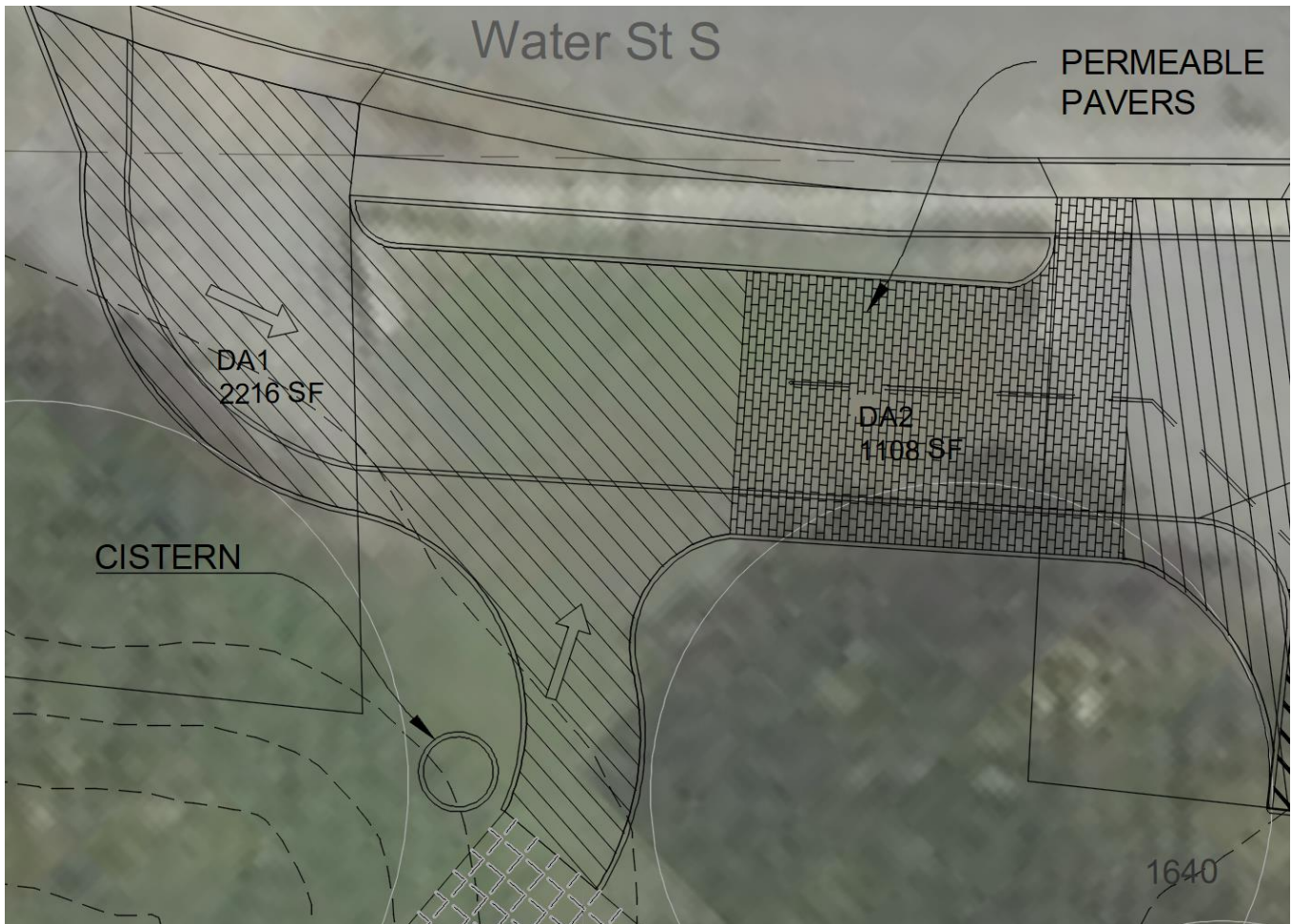

The cross-section profile for this type of paver is shown below.

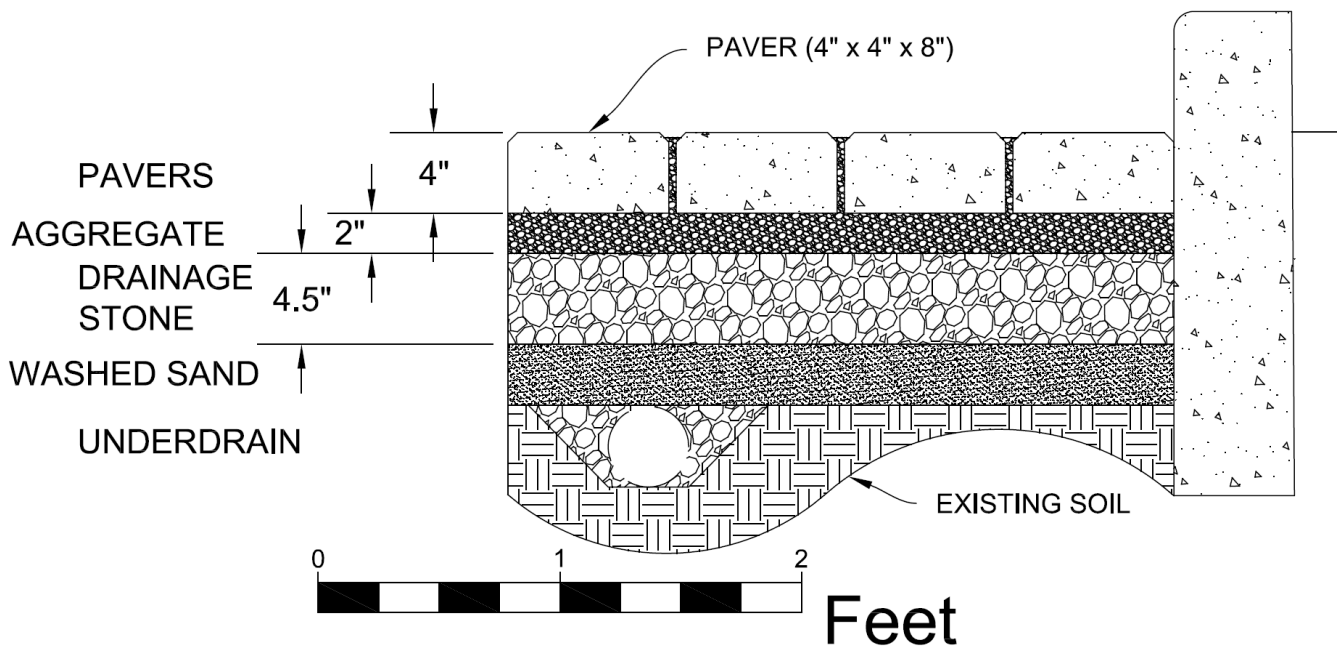

The paver is 4" thick, the typical depth of the installation aggregate is 2", the depth of the drainage stone layer is determined using the following equation.

$$\begin{aligned}
 D_{\text{drainage stone}} &= \text{Target Volume (CF)} / \text{Area of permeable pavement (SF)} \\
 &= 415.5 \text{ CF} / 1108 \text{ SF} \\
 &= 0.375 \text{ F} = 4.5 \text{ "}
 \end{aligned}$$

This is the minimum depth for the drainage stone layer. A civil engineer may modify this section to meet load requirements. The entire pervious area must be surrounded by flush curb or full curb; these serve as edge restraints to protect the edge and keep the pavers from moving.



## Rainwater Harvesting / Cistern – Site 1

The roof of the new building is designed so the whole roof slopes toward the front of the building. This allows the entire roof drainage to be collected along one edge. A gutter designed with a high point at the mid-point of the gutter divides roof drainage so that half flows one way and half the other. Two cisterns, one on each side, are placed at the corner of the building to capture runoff. The building and cisterns are shown below.



In order to size each cistern, first calculate the Target Volume.

$$\begin{aligned} \text{Target Volume (cubic feet)} &= \text{drainage area (square feet)} \times \text{treatment rainfall (feet)} \\ &= \text{roof area SF} \times 0.125 \text{ F} \\ &= 4644 \text{ SF} \times 0.125 \\ &= 580.5 \text{ CF} \end{aligned}$$

Cisterns are usually specified in gallons. Here is the conversion.

$$580.5 \text{ CF} \times 7.48 \text{ gal./CF} = 4312 \text{ gal.}$$

Divide this number by 2 since there are 2 cisterns.

$$4312 \text{ gal} / 2 \text{ cisterns} = 2171.1 \text{ gal. / cistern}$$

A quick search online produces a simple metal cistern with a capacity of 2200 gal. The dimensions of this cistern are 7' diameter – 7'-8" height.

A cistern that exerts more than 2000 pounds / square foot requires a concrete foundation. Calculate the pressure exerted by each cistern using the equations below.

$$\begin{aligned} \text{Weight of Cistern} &= \text{Capacity (gal.)} \times 8.32 \text{ (pounds/gal.)} \\ &= 2200 \text{ gal.} \times 8.32 \text{ pounds/gal.} \\ &= 18304 \text{ pounds} \end{aligned}$$

$$\begin{aligned} \text{Contact area (SF)} &= \text{area of circle} = \pi \text{ (diameter (F)/2)}^2 \\ &= \pi (7/2)^2 \\ &= 38.5 \text{ SF} \end{aligned}$$

$$\begin{aligned} \text{Pressure exerted by Cistern (pounds / SF)} &= \text{Weight of Cistern (pounds)} / \text{contact area (SF)} \\ &= 18304 \text{ pounds} / 38.5 \text{ SF} \\ &= 475 \text{ pounds / SF} \end{aligned}$$

Each cistern can be placed on a gravel foundation.

Provide reference to the proposed cistern including manufacturer, model number and website if available.



## Vegetated Filter Strip Design – Site 2

A parcel is developed as a parking lot for an adjacent business. This parcel borders existing turf to the north and east. The designer has decided to treat as much of the parking lot as possible using a vegetated filter strip. Ten parking spaces are required. Angled spaces are used to minimize the total impervious area. A ridge is incorporated into the design forming two distinct impervious drainage areas. The ridge is strategically placed to meet the maximum dimension requirements. Drainage area 2 (DA2) is designed to slope towards the edge that will drain to the vegetated filter strip. The slope is approximately 4.5% and perpendicular to the flush curb edge so stormwater runoff can sheet flow to the vegetated filter strip. Refer to figure below:

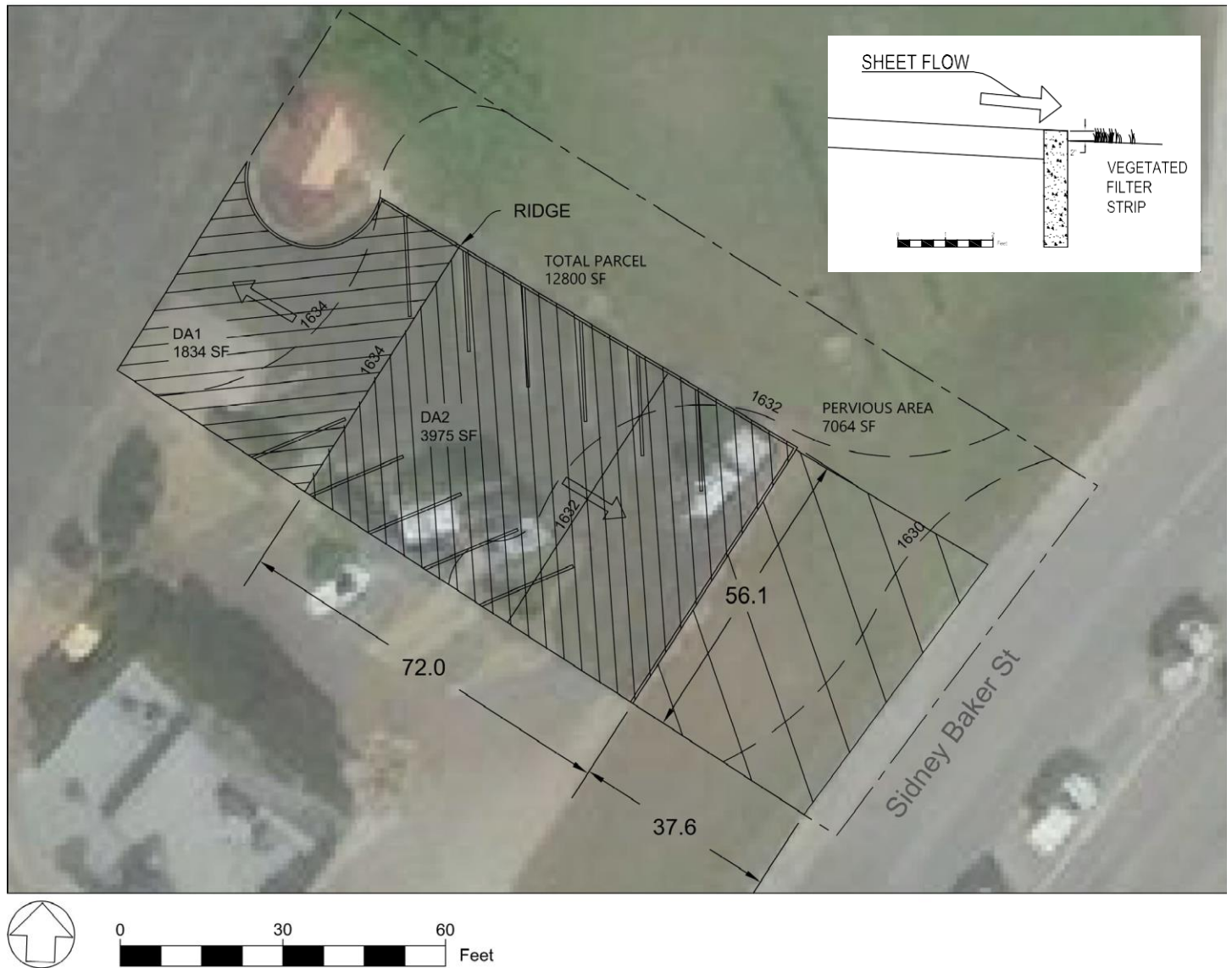

This design meets the requirements for an Engineered Filter Strip outlined in the Design Steps from [Complying with the Edwards Aquifer Rules: Technical Guidance on Best Management Practices](#).

1. Filter strip extends along entire length. Slope of filter strip is less than 20%. The width (distance perpendicular from edge) does not exceed 72 feet.
2. Minimum dimension in direction of flow is greater than 15 feet; shown as 37.6 feet in plan.
3. Vegetated filter strip is completely vegetated with turf.
4. Contributing area is relatively flat and has a level edge.
5. No existing gullies or rills.
6. Top edge has 2 inch drop off to vegetated filter strip.

For this example, the calculation of Treated Volume is shown below.

$$\begin{aligned}
 \text{Treated Volume (cubic feet)} &= \text{drainage area (square feet)} \times \text{treatment rainfall (feet)} \times 60\% \\
 &[\text{Equation 5}] \\
 &= 3975 \text{ SF} \times 0.125 \text{ F} \times 60\% \\
 &= 298.13 \text{ CF}
 \end{aligned}$$

## Riparian Buffer Design Example – Site 1

A parcel is developed adjacent to the Guadalupe River. Other nature-based methods are used to treat stormwater runoff from impervious drainage areas. The designer has decided to maximize treatment by preserving an existing riparian buffer. Refer to the figure below for the boundary of the buffer and calculations.



1. The riparian buffer is adjacent to the Guadalupe River and extends the entire length of the waterfront.
2. The buffer length is approximately 210 feet, and the buffer width is approximately 50 feet.
3. The boundary of restricted activities and inventory activities is shown and labeled on the Project Drawing.

## **Appendix C – Summary of General Maintenance Requirements**

---

The following are example maintenance schedules that describe suggested routine maintenance for each treatment method. UGRA recommends the use of maintenance schedules that can be adapted based on in-person observations.

# Bioretention Maintenance Schedule

Year: \_\_\_\_\_

Location: \_\_\_\_\_

	January	February	March	April	May	June	July	August	September	October	November	December
<b>Drainage Area</b>												
Free of excessive sediment/dirt												
Free of excessive leaves												
Free of excessive oil / grease												
<b>Forebay or Filter strip</b>												
Remove sediment > than 1"												
Check for erosion and correct												
Remove any unwanted plants												
Remove any trash												
<b>Basin</b>												
Check for erosion & correct												
Check 3" of hardwood mulch & correct												
Check for compacted mulch & correct												
Remove any sediment in basin												
Check Plants, trim, remove weeds												
Remove any trash												
<b>Overflow</b>												
Overflow pipe screen unclogged												
Overflow pipe inlet clear												
Inspect cleanout and outlet												
<b>Berm / Surrounding Area</b>												
Check for erosion & correct												
3" of hardwood mulch (if mulched)												
Check Plants, trim, remove weeds												
Remove any trash												

	Inspector Name, Date	Notes
Jan	_____	_____
Feb	_____	_____
Mar	_____	_____
Apr	_____	_____
May	_____	_____
Jun	_____	_____
Jul	_____	_____
Aug	_____	_____
Sep	_____	_____
Oct	_____	_____
Nov	_____	_____
Dec	_____	_____

# Permeable Pavement Maintenance Schedule

Year: \_\_\_\_\_

Location: \_\_\_\_\_

	January	February	March	April	May	June	July	August	September	October	November	December
<b>Drainage Area &amp; Conveyance</b>												
Free of excessive sediment/dirt												
Free of excessive leaves/other materials												
<b>Permeable Area</b>												
Free of excessive sediment/dirt												
Free of excessive leaves/other materials												
Check for obstructions or ponding*												
Inspect pavers & correct												
Professionally vacuum permeable area												
Replace joint material as needed												
<b>Overflow</b>												
Inspect cleanout												
Inspect outlet orifice and correct												
<b>Other</b>												
*note - ponding must be corrected by infiltration test												
more frequent vacuum treatment												

	Inspector Name, Date	Notes
Jan	_____	_____
Feb	_____	_____
Mar	_____	_____
Apr	_____	_____
May	_____	_____
Jun	_____	_____
Jul	_____	_____
Aug	_____	_____
Sep	_____	_____
Oct	_____	_____
Nov	_____	_____
Dec	_____	_____

# Cistern Maintenance Schedule

Year: \_\_\_\_\_

Location: \_\_\_\_\_

	January	February	March	April	May	June	July	August	September	October	November	December
<b>Drainage Area &amp; Conveyance</b>												
Free of excessive sediment/dirt												
Free of excessive leaves/obstructions												
Gutters operating as designed												
<b>First Flush</b>												
Check for obstructions & clear												
Check drainage & correct												
Check for sediment buildup & clean												
<b>Cistern</b>												
Inspect filters, screens & clean												
Check drainage time, < 144 hours												
Check for leaks & correct												
Check drain valve operation												
Verify all access locked												
Inspect foundation & correct												
Verify safety signage												
<b>Overflow</b>												
Check vector screens & correct												
Inspect overflow path & correct												
Verify overflow path infiltrates/drains												
<b>Other</b>												
Internal inspection every 5 years												

	Inspector Name, Date	Notes
Jan	_____	_____
Feb	_____	_____
Mar	_____	_____
Apr	_____	_____
May	_____	_____
Jun	_____	_____
Jul	_____	_____
Aug	_____	_____
Sep	_____	_____
Oct	_____	_____
Nov	_____	_____
Dec	_____	_____

# Vegetated Filter Strip Maintenance Schedule

Year: \_\_\_\_\_

Location: \_\_\_\_\_

	January	February	March	April	May	June	July	August	September	October	November	December
<b>Drainage Area &amp; Conveyance</b>												
Free of excessive sediment/dirt												
Free of excessive leaves/other materials												
Check for obstructions on drainage edge												
Check edge dropoff to strip > 1" & correct												
<b>Vegetated Filter Strip</b>												
Remove sediment at edge > than 1"												
Check for erosion and correct												
Check Plants, trim, remove weeds												
Remove any trash												
Check for ponding and correct												
Verify original dimensions not modified												

Inspector Name, Date	Notes
Jan	_____
Feb	_____
Mar	_____
Apr	_____
May	_____
Jun	_____
Jul	_____
Aug	_____
Sep	_____
Oct	_____
Nov	_____
Dec	_____

# Riparian Buffer Maintenance Schedule

Year: \_\_\_\_\_

Location: \_\_\_\_\_

	January	February	March	April	May	June	July	August	September	October	November	December
<b>Drainage Area &amp; Conveyance</b>												
Check for erosion and correct												
Free of excessive sediment/dirt												
Verify information signage												
Verify buffer boundary is visible/marked												
<b>Riparian Buffer</b>												
Verify buffer dimensions												
Verify no restricted uses in buffer												
Remove any trash												
Conduct plant inventory												
Remove noxious and invasive plants												
Photo document												
Assess plant health												

	Inspector Name, Date	Notes
Jan	_____	_____
Feb	_____	_____
Mar	_____	_____
Apr	_____	_____
May	_____	_____
Jun	_____	_____
Jul	_____	_____
Aug	_____	_____
Sep	_____	_____
Oct	_____	_____
Nov	_____	_____
Dec	_____	_____





# Water Resources Preservation Grant Program

## Application

### Program Description

The Water Resources Preservation Grant Program is an incentive program funded by UGRA. The program provides cost share funding for design and construction of stormwater management practices commonly referred to as best management practices (BMPs). The program provides rebates for a portion of the cost of specific management practices that reduce, infiltrate, filter, and delay stormwater runoff. These types of practices fall under the umbrella terms of Low Impact Development (LID), nature-based solutions, and Green Stormwater Infrastructure (GSI). Stormwater management practices must be designed and constructed using the guidance provided in this document. The program is open to new construction or retrofit of existing property.

### Program Details

- Interested applicants should contact UGRA and schedule a pre application meeting as soon as possible during the project planning process
- One application per project (applicant can reapply for future construction phases and those applications will be evaluated as standalone projects)
- Applications are accepted year-round
- No limit on number of stormwater management practices per project
- Design and construction must follow guidance from this document
- Design is based on runoff volume from 1.5" 24-hour event
- Projects treating at least 60% of runoff from impervious surfaces will receive priority Projects are scored based on a published rubric
- Eligible projects must have a minimum score of 10 on the published rubric
- List of eligible stormwater management practices include:
  - Bioretention
  - Permeable Pavement
  - Rainwater Harvesting / Cistern
  - Vegetated Filter Strip
  - Riparian Buffer
- Project must include installation of interpretive signage for each management practice (UGRA will provide selected applicants with sign content).
- Rebate:
  - Minimum rebate \$20,000
  - Maximum rebate \$150,000
  - Number of projects approved per year is contingent upon funds budgeted by the UGRA Board
  - Rebate is only for design and construction of stormwater management practices
  - Rebate agreement signed by landowner is required which will include an expectation for continued operation and maintenance of the practices for which the rebate was provided
  - Rebate funds are paid after project is complete and an approved inspection by UGRA personnel
  - Rebate is payable to landowner only

## Eligibility

The program is open to projects located within Kerr County, except:

1. Single family residential projects
2. Small projects with stormwater treatment cost estimate less than \$20,000

## Application

To apply to the program, submit the following documents:

1. Complete **Application Form**
2. Written **Project Narrative** that includes the following information:
  - a. Project description
  - b. Details on how project meets the goals of the program
  - c. Estimated cost of nature-based practices
  - d. Estimated amount of cost share rebate requested
  - e. Impact on receiving water body (i.e. anticipated reduction in adverse impacts such as erosion or sedimentation)
  - f. Details on operation and maintenance
  - g. Project location, easements, public access
  - h. Details on commitment to the project (i.e. anticipated educational opportunities to promote BMPs, owner's financial commitment to BMPs, prior experience with similar BMPs)
  - i. Details on drainage areas and BMP treatment
3. **Project Drawing**, a plan view drawing that includes the following information in order to illustrate a conceptual design (sealed designs are not required for the application).
  - a. Property boundary and area
  - b. Boundaries and dimensions of all impervious areas
  - c. Boundaries and dimensions of all drainage areas
  - d. Boundaries and dimensions of all existing riparian areas (if applicable)
  - e. Boundaries and dimensions of all riparian areas proposed for restoration and preservation (if applicable)
  - f. Existing contours with elevation
  - g. Proposed contours with elevation
  - h. Hydrologic Soil Group (HSG) boundary (refer to references for info)
  - i. Hydrologic Soil Group (HSG) label
  - j. Proposed treatment best management practice(s)
  - k. Cross-section for each best management practice(s). This can be a conceptual cross section based on the example designs in Appendix B of the program guidance.
  - l. All BMP dimensions
  - m. Calculations for Target Volume
  - n. Calculations for Treatment Volume
4. Complete **Treatment Worksheet**

# Application Form

An application is complete if it has an **Application Form** with all fields completed, a written **Project Narrative** with all required information, a **Project Drawing** with all required information, and a **Treatment Worksheet** with all the required information. You will be notified when the application is considered accepted.

Please review complete program guidelines.  
 Available here: <http://www.ugra.org/major-initiatives/water-resources-preservation-grant-program>

## Project Details

Project Name			
Project Address			
City	State	ZIP	County
<b>Primary Contact</b>			
Name		Title	
Phone		Email	
<b>Project Partners</b>			
Company/Person		email, phone	
Developer			
Architect			
Geotechnical Engineer			
Landowner			
Civil Engineer			
Landscape Architect			
Contractor			
<b>Project Timeline</b>			
Start Date		End Date	
Construction Start Date		Construction End Date	

	Exemplary (3 pts)	Adequate (2 pts)	Needs Improvement (1 pt)	Missing (0 pts)	Score	Comments
<p><b>Project Description</b></p> <p>Project description on application is used to evaluate how this project meets the goals of the program.</p>	Provides clear and complete description	Provides description that is limited or does not address goals	Provides description that is not related to goals	Description not provided		
<p><b>Amount of Treatment</b></p> <p>Project plan documents should show calculations for Target Volume, Treated Volume and % Treated Volume.</p>	Maximizes treatment of stormwater using BMPs as needed  % Treated Volume >= 100%	Provides adequate treatment of stormwater  75% <= % Treated Vol < 100%	Provides minimal treatment of stormwater  60% <= % Treated Vol < 75%	Provides less than required treatment of stormwater  % Treated Vol < 60%		
<p><b>Impact on Receiving Body</b></p> <p>An existing stormwater network could effectively result in your project being closer to a receiving body. Show SW networks.</p>	Stormwater drains directly to creek, stream or river within 0.25 mile	Stormwater drains directly to creek, stream or river within 0.5 mile	Stormwater drains directly to creek, stream or river within 1.0 mile	Stormwater drains directly to creek, stream or river over 1.0 mile away		
<p><b>Operation and Maintenance</b></p> <p>Project description on application is used to evaluate how this project plans for O&amp;M.</p>	Application clearly states all details of operation and maintenance including who, what, how, and when including funding mechanisms	Application states some details of operation and maintenance	Application shows few details of operation and maintenance	Application does not cover operation and maintenance		
<p><b>Location</b></p> <p>Projects in priority locations are prioritized - UGRA owned land, obtained easement, publically accessible, publically visible.</p>	Project has three priority location indicators	Project has two priority location indicators	Project has one priority location indicator	Project does not have any location priority indicators		
<p><b>Commitment</b></p> <p>Examples: corporate commitment, treatment beyond minimum requirements, O&amp;M commitment beyond 10 years or enhanced demonstration.</p>	Project demonstrates three or more examples of commitment	Project demonstrates two examples of commitment	Project demonstrates one example of commitment	Project does not demonstrate examples of commitment		
<p><b>Riparian Function</b></p> <p>Project includes riparian area restoration or preservation.</p>	Maximizes riparian function  Riparian width >= 50 ft. Riparian length >= 90% of entire length of waterfront	Provides adequate riparian function  30 ft. < Riparian width < 50 ft. 85% < Riparian length < 90% of entire length of waterfront	Provides minimal riparian function  Riparian width = 30 ft. Riparian length = 85% of entire length of waterfront	Project does not address riparian function or does not meet minimum riparian buffer size		
Total Score						